

IN10CT FUNCTIONAL TRAINER

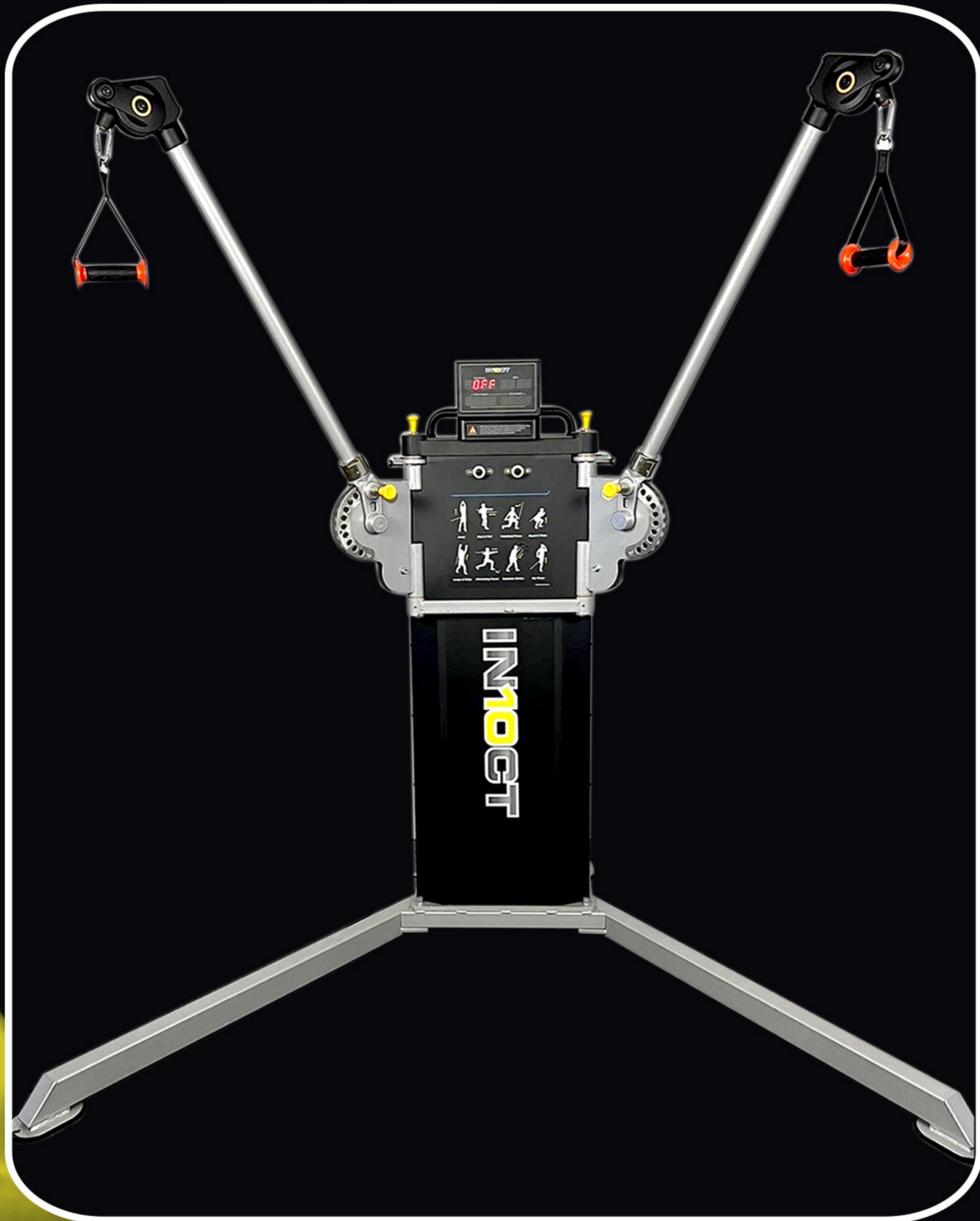

IN10CT (Intensity) Functional Trainer uses compressed air for resistance, which is quickly and easily adjustable with just a push of a button.

The pneumatic resistance gives a silky-smooth feel without impact and allows for explosive movements for sports performance, speed and power or subtle movements for exercise rehab.

The functional arms move up and down as well as in and out allowing for multiple angles and 100's of exercises.



The **IN10CT** Functional Trainer is freestanding, or you can bolt to the floor or hang from a wall.

Transport wheels and handle bar allow you to easily move around the facility floor.

Has its own air compressor built inside the machine, so no separate unit required.

Electric console measure Resistance, Repetitions and Peak Power.



Features:

- Built in air compressor
- Adjustable arms, Vertically and horizontally
- Free standing or bolt to the wall or floor
- Optional Battery Pack - to use anywhere

Specifications:

- Maximum Wt. Capacity: 30kg/ 65lbs
- Product Dimension: 85*59*64inches
- Product Total Space: 118*26*95 inches

